



Guidelines for inspection and servicing
A-frames/Drawbar eyes
2022

General information

General information

The components used to connect a vehicle and trailer are exposed, even during normal use, to very high tensions. Regular service and maintenance is a prerequisite if the drawbar is to function well for the duration of its service life.

The length of the service intervals depend on the type of trailers, the loads, roads and climatic conditions etc. The service should ideally be carried out in conjunction with other inspection of the vehicle, e.g. every 60,000 or 90,000 km.

If daily inspection or safety checks show that the function of the product has been impaired, servicing must be carried out immediately.

If any of the product's wear limits have been exceeded, this is an indication that other parts also require servicing.

Check that all type plates and warning/information labels are legible and have not been painted over, washed off or otherwise damaged. Illegible labels must be replaced and can be ordered from VBG Truck Equipment.

If the drawbar/drawbar eye is damaged due to e.g. jackknifing, or collision, the drawbar/drawbar eye must be replaced.

NB! All equipment must be depressurised and without voltage before servicing is carried out. This means that you must disconnect the supply air and the power to drawbars.

Always follow the vehicle manufacturer's bodybuilding instructions.

Guidelines for inspection and servicing Drawbars/Drawbar eyes 2022

© VBG GROUP TRUCK EQUIPMENT GMBH

11/2022 - Id. -Nr. 10090738a

The content of this publication may not be reproduced either in full or in part without the prior approval of VBG GROUP TRUCK EQUIPMENT GMBH.

This prohibition is applicable for all forms of reproductions in all types of media, including electronic media.

Explanation of symbols



Warning!

Never put your fingers into the coupling mouth as they may be crushed. An open coupling always involves a risk of crushing.



Severity







3 = STOP to ensure future use.
2 = Rectify as soon as possible, within four weeks.
1 = Rectify when able or during next service. Within no more than one year.

		Torque (Nm)	
Size	Quality	Nut	
M24		300	
Kronemutter		500	

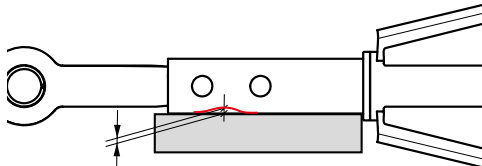

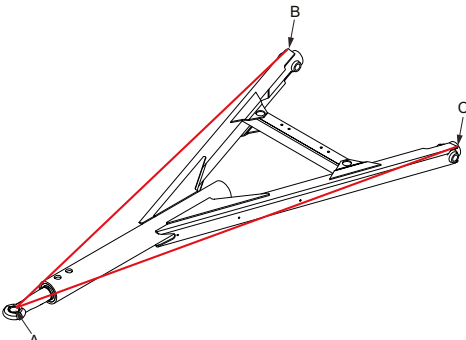

Prescribed tightening torques apply to bolt kits supplied by VBG Group Truck Equipment GMBH.

General information on drawbars and drawbar eyes	4
General information on hinged brackets	8
Drawbar TBZ, PZG, PZL, PZLG, PZGL, PZS, PZSG, SL, ZGS, PZM/PZMS	12
General information on drawbar eyes	14

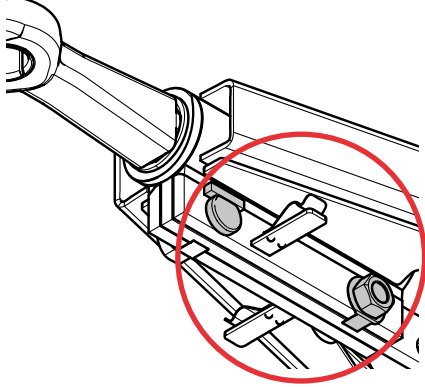
Checkpoint	Symptom	Fault
<p>Typeplate. Drawbar eye. Bushing/bearing eye.</p>		
<p>Legs, crossbar, gussetplate.</p>	<p>Deformations. The trailer does not “track” the vehicle. Marks from straightening work such as in very heat-affected zones. Welds.</p>	<p>Dents, kinks, twists and bent sheet metal parts such as side members, front and rear sliders, cross member, etc.</p>
<p>Legs, crossbar, gussetplate.</p>	<p>Deformations. Cracked, flaking paint. Thin streaks where dust and dirt are not present. Streaks that are rust-coloured. Visible cracks, any rust marks around the crack.</p>	<p>Cracks.</p>
<p>Complete drawbar.</p>	<p>Be aware of noise when driving and if the trailer veers sideways.</p>	<p>Geometric error in the A-shape.</p>

<p style="text-align: center;">Inspection method</p> <p>Attachment, damage, wear, play. – Visual check of attachment, damage and wear. The term attachment also covers the eye attachment in the drawbar and the wear ring's attachment in the drawbar eye. – Rust damage check using tools is performed when corrosion is found. – Play check of drawbar bearing and extension mechanism. This check is done by applying the trailer brake and rocking the traction vehicle. – Jackknifing damage/repairs/welds. – Wear, eyes/bushings.</p>	<p style="text-align: center;">Requirements, wear limits, etc.</p>	<p style="text-align: center;">Instructions for rectification</p>
<p>Check that none of the parts are deformed. Deformation may arise in connection with jackknifing, reversing or other external influences.</p>	<p>Generally, no deformations are permitted. Deviation from theoretical surface/shape greater than the specified dimensions is considered to be a deformation. No welding or warping is permitted. Deviation/length 5 mm/1,000 mm 3 mm/150 mm</p> 	<p> In the event of deformation, warping or welds, visit the workshop and replace the damaged parts. ① ② ③ ② When the components have been dismantled, they must be re-tightened after driving 2,500 km.</p>
<p>Check that none of the parts are cracked. The greatest risk of cracking is close to bend radii, welds and hole edges.</p> 	<p>No cracks are permitted. No welding or other repairs are permitted.</p>	<p> In the event of cracking, stop driving and immediately visit a workshop, replace damaged parts. ① ② ③ ③ After replacing damaged parts, tightening takes place after driving 2,500 km.</p>
<p>Cross-measure between the centre of the eye and each rear bracket.</p>	<p>Dimensions: $ab = ac \pm 2 \text{ mm}$.</p> 	<p> Replace any defective materials and adjust. ① ② ③ ② After any replacement of damaged parts and adjustment of the geometry, retightening must be performed after driving 2,500 km. Use the installation instructions for any a djustment.</p>

Checkpoint	Symptom	Fault
<p>Bolted joint.</p>	<p>Scuff marks around bolted joints. Rust around bolt heads/nuts. Squeaking/clicking sound.</p> 	<p>Loose or missing bolts.</p>
<p>Legs, crossbar, gussetplate.</p>	<p>The surface treatment is flaking/ chipped. Rusty water flows out from cavities/ partially closed cavities. Loose rust flakes/"soft" material/ porosity in the base metal.</p>	<p>Corrosion. "Pitting".</p>
<p>Complete drawbar.</p>	<p>The surface treatment is flaking/ chipped. Rusty water flows out from cavities/partially closed cavities.</p>	<p>Corrosion. Surface rust.</p>

<p style="text-align: center;">Inspection method</p> <p>Be aware of banging/clicking sounds or jolts when driving with a trailer. Check whether rust has formed around the bolt heads and around holes where any bolts have been. Check to see if there has been any movement in the bolted joints. Check whether any rotation occurs during testtightening to the prescribed tightening torque in accordance with the table on page 2.</p>	<p style="text-align: center;">Requirements, wear limits, etc.</p> <p>No movement is permitted in the bolted joint and there should be no rotation during test-tightening to the prescribed tightening torque. Prescribed tightening torques apply to bolt kits supplied by VBG Group Truck Equipment GMBH.</p>	<p style="text-align: center;">Instructions for rectification</p> <p> ① ② ③ In the event of movement in the bolted joint, stop driving and visit a workshop immediately. Dismantle/check constituent parts and replace any that are damaged.</p> <p>③ If there is too low a tightening torque, visit a workshop. Dismantle/check constituent parts and replace any that are damaged. When the components have been dismantled, they must be re-tightened after driving 2,500 km. Examples of damage. – Deformed holes – Damaged threads – Scuff marks on bolts – Fretting damage</p>
<p>Check regularly that there is no corrosion damage such as “pitting”. Take particular note of cavities and partially enclosed areas etc.</p>  <p>Side member that has rusted through</p>	<p>“Pitting” should not occur; particular attention should be paid to the inside of cavities and partially enclosed areas.</p>	<p> ① ② ③ In the event of pitting, stop driving and immediately visit a workshop. In the event of pitting, damaged parts must be replaced. Welding is not permitted.</p> <p>③</p>
<p>Take particular note of cavities and partially enclosed areas, etc.</p>	<p>Surface rust or red rust must be dealt with urgently.</p>	<p> ① ② ③ Remove external rust using a blast-cleaner or a steel brush, and then reapply corrosion protection.</p> <p>①</p>

Checkpoint	Symptom	Fault
Hinged bracket, type Silent bushing.	Meandering trailer, high degree of longitudinal movement, loose rubber residue outside of the silent bushing, noise.	Significant movement in the hinged brackets, type Silent bushing, due to worn rubber.
Hinged bracket, type Silent bushing.	Meandering trailer, significant movement longitudinally, noise.	Significant movement in the hinged brackets, type Silent bushing, due to play between the hinged bracket's centre housing and the hinged bracket's ears at the front of the trailer.

Inspection method

Be aware of noise or jerks when driving with a trailer.
Check using a crowbar that there is no play/movement exceeding ± 5 mm in the hinged brackets. It is also possible to apply the trailer brake while pulling slightly with the cab to assess the play/movement between the pivot bolt/nut and the rear bracket ears on both the right and left sides.

Requirements, wear limits, etc.

No obvious play/movement exceeding ± 5 mm may occur and the movement must be equal on the right and left sides.

Instructions for rectification



If the movement exceeds ± 5 mm, visit a workshop, replace damaged parts.

2

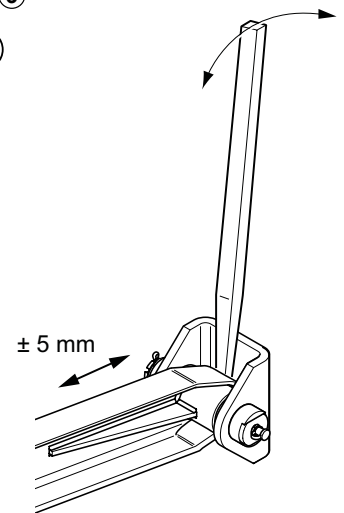

Be aware of noise or jerks when driving with a trailer. Check whether there is rust on the contact surfaces around the head of the pivot bolt or the nuts and/or scuff marks between the centre housing and the rear bracket's ears. Check using a crowbar that there is no play/movement between the centre housing and the ears of the rear bracket. It is also possible to apply the trailer brake while pulling slightly with the cab to assess the play/movement between the pivot bolt/nut and the rear bracket ears on both the right and left sides. Check the tightening torque, 650 Nm.

No play or movement is permitted.



3

In the event of movement/play between the pivot bolt and the ears of the hinged bracket, stop driving and immediately visit a workshop to replace damaged parts. When the components have been dismantled, they must be re-tightened after driving 2,500 km.

Tightening torques 600-650 Nm.

Examples of damage.

- Deformed holes
- Damaged threads
- Scuff marks on the pivot bolt
- Fretting damage

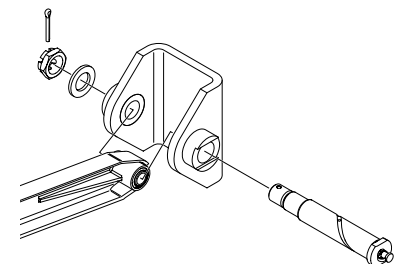

Checkpoint	Symptom	Fault
Hinged bracket, type Silent bush.	Meandering trailer, high degree of longitudinal movement, sometimes with a rattling sound when the pivot bolt hits against the ears' hole edges.	Significant movement in the hinged brackets, type Silent bush, due to loose or broken pivot bolt; the pivot bolt slides radially.
Hinged bracket, plastic and brass bushings.	Meandering trailer, significant movement longitudinally.	Significant movement in the hinged brackets, plastic and brass bushings, due to worn rubber.

Inspection method

See if there is rust on the contact surfaces around the head of the pivot bolt or nuts.
Check for scuff marks between the pivot bolt and the ears of the rear bracket.
Check using a crowbar that there is no play in the rear brackets.
It is also possible to apply the trailer brake while pulling slightly with the cab to assess the play/movement between the pivot bolt/nut and the hinged bracket ears on both the right and left sides.

Requirements, wear limits, etc.

No gap or movement is allowed.

Instructions for rectification



In the event of movement/play between the pivot bolt and the ears of the hinged bracket, stop driving and immediately visit a workshop to replace damaged parts.

When the components have been dismantled, they must be re-tightened after driving 2,500 km.

Tightening torques 600-650 Nm.

Examples of damage.

- Deformed holes
- Damaged threads
- Scuff marks on the pivot bolt
- Fretting damage

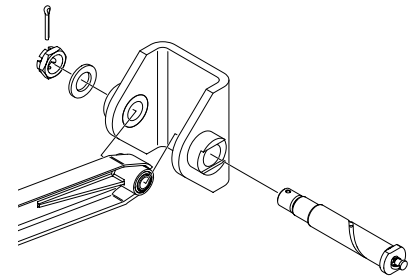

Be aware of noise or jerks when driving with a trailer.
Check, with the aid of a crowbar, that there is no play in the hinged brackets.
It is also possible to apply the trailer brake while pulling slightly with the vehicle to assess whether the play and movement are the same on both the right and left sides.

There should be no obvious play.



In the event of play, visit a workshop to replace damaged parts. When the components have been dismantled, they must be re-tightened after driving 2,500 km.

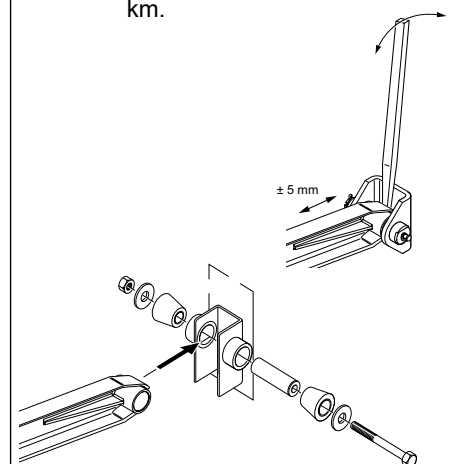

Checkpoint	Symptom	Fault
Legs and cross members. TBZ, ZGS	Paint chipped/cracked or deformed sections.	Reduced durability due to the drawbar eye, side member, front slider or other part being deformed/curved/dented/kinked or having cracks.
Bolted joint. PZL, PZGL, PZLG	Discolouration of bolted joints, marks from micro-movements (no dirt or dust around the overlap plates, bolt heads, etc.) or larger scuff marks.	Banging/clicking sounds while driving due to loose or missing bolts.

Inspection method

No deformation or cracks are allowed. Deviation from theoretical surface/shape greater than the specified dimensions is considered to be a deformation. Check whether there are any welds or warping. Check regularly or if you suspect any abnormal stress may have affected the drawbar that there is no deformation or cracking.

Requirements, wear limits, etc.

No deformation or cracks are allowed. Deviation from the theoretical surface/shape greater than the specified dimensions is considered to be a deformation. Check whether there are any welds or warping. Check regularly or if you suspect any abnormal stress may have affected that the drawbar, that there is no distortion or cracking.

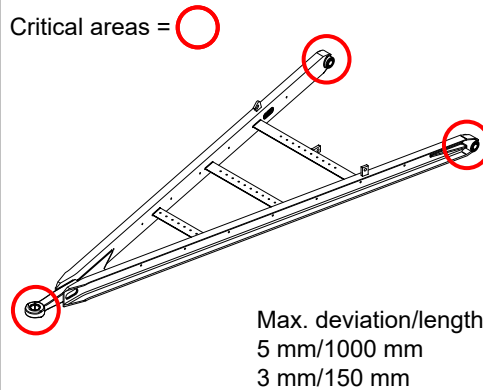

Instructions for rectification



In the event of cracking, stop driving and immediately visit a workshop, replace damaged parts.

③

②

In the event of deformation, warping or welds, visit the workshop and replace the damaged parts.

Be aware of rust around bolt heads as well as holes where there have previously been bolts. Check to see if there has been any movement in the bolted joints. Check whether any rotation occurs when tightened to the prescribed tightening torque according to the table (see section Drawbars, General information) for M24.

No movement is allowed and there should be no rotation when test tightened to the prescribed torque. No movement of the Pull Rod when screws are tightened with tools or hand lever.

Critical areas = 

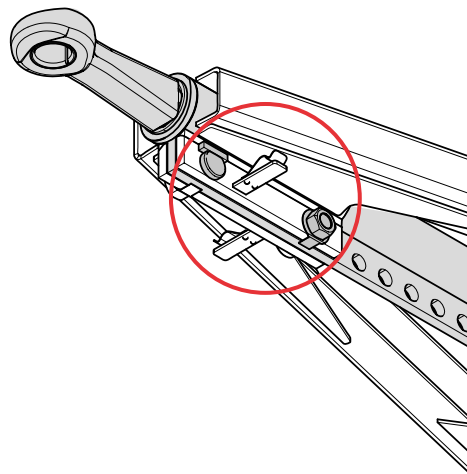

In the event of any movement or insufficient tightening torque, visit a workshop, disassemble and inspect the parts.

②

③

If there are any damaged parts, these must be replaced. When the components have been dismantled, they must be re-tightened after driving 2,500 km. Examples of damage:

- Deformed holes
- Damaged threads
- Cut marks on bolts
- Fretting damage

<p>Bolted joint.</p>	<p>Noise, rattling, clicking, scuff marks, absence of dirt/dust around bolt heads and overlap joints, discolouration of rust-coloured water.</p>	<p>Loose or missing bolts/nuts.</p>
<p>Bushing/wear ring.</p>	<p>Connection and/or disconnection problems. Bushing/wear ring axially displaced. The wear ring is not level with the eye.</p>	<p>Loose or damaged bushing/wear ring.</p>
<p>Bushing/wear ring/drawbar eye.</p>	<p>The trailer "jolts" if the road is uneven. Rattling/noise.</p>	<p>Worn bushing/wear ring/drawbar eye.</p>
<p>Bushing/wear ring/drawbar eye.</p>	<p>Be aware of whether the coupling triggers during connection and disconnection, and of noise when driving. Check the height dimension of the eye on the most worn surface.</p>	<p>Drawbar eye/wear ring vertically very worn or pitting in the supporting surfaces.</p>

Be aware of popping/clicking sounds or jerks when driving with a trailer.
 Be aware of rust around bolt heads as well as holes where there have previously been bolts.
 Check to see whether there has been any movement in the bolted joint.
 Check whether there is any rotation when test-tightened to the prescribed tightening torque.

No movement between parts is permitted and there should be no rotation during test tightening to the prescribed tightening torque. All bolts must be fitted.



① ② ③

③

In the event of movement in the bolted joint, stop driving and visit a workshop immediately. Dismantle/check constituent parts and replace any that are damaged.

②

If there is too low a tightening torque, visit a workshop. Dismantle/check constituent parts and replace any that are damaged. When the components have been dismantled, they must be re-tightened after driving 2,500 km.

Check whether the drawbar is difficult to connect or disconnect.
 Check whether the bushing in the eye is loose by tapping lightly with a hammer on the bushing/wear ring.

The bushing must be secure and in the correct position. There should be no movement.



① ② ③

②

In the event of a loose wear ring/bushing, visit the workshop to replace the damaged material

Measure the bushing's max. diameter D.

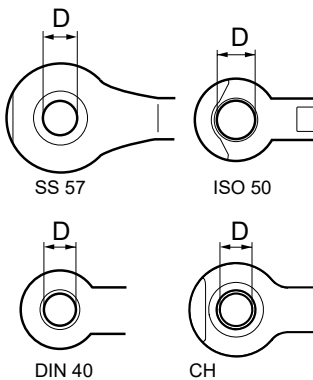

The wear limits for the bushing/wear ring in the drawbar eye are indicated in table.

Type	Max. D (mm)
SS 57	59.5
ISO 50	52
DIN 40	42
CH	42



① ② ③

②

Replace the wear ring/bushing no later than when max. D has been reached.

NB: Welding is prohibited.

Check whether the coupling triggers during connection and disconnection, and whether rattling and noise is heard during driving.
 Measure the eye's height dimension T on the most worn surface.

Each drawbar eye's minimum dimension must be achieved.

Type	Min. T (mm)
SS 57	19
NATO	37
ISO 50	42.5
DIN 40	28
CH	38



① ② ③

②

Replace the drawbar eye if it is thinner than specified dimension T.

NB: Welding is prohibited

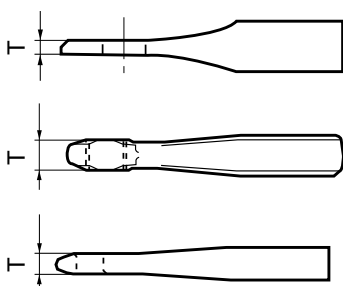

Checkpoint	Symptom	Fault
<p>The drawbar eye's outer geometry.</p>	<p>Difficult to connect.</p>	<p>Worn down outer radius.</p>
<p>The drawbar eye's outer geometry.</p>	<p>Marks from jackknifing on endplates, drawbar, etc. Marks from the tipper body, top of the drawbar. The drawbar eye is not sitting symmetrically in the drawbar.</p>	<p>Bent drawbar eye due to overloading.</p>
<p>The drawbar eye and its attachment.</p>	<p>Rust residue around a possible crack. Cracked paint. Other damage in connection with jackknifing.</p>	<p>Cracks in the drawbar eye and in connection with the drawbar eye attachment in the front slider.</p>
<p>Contact surfaces drawbar eye/ sleeve/castellated nut for drawbar eyes 40/50/57/Nato76 fitted with castellated nuts.</p>	<p>Noise, rattling, clicking, scuff marks, absence of dirt/dust in the transition section between the sleeve and drawbar eye, and discolouration of rust-coloured water is in evidence.</p>	<p>Play between sleeve, drawbar eye and castellated nut.</p>

Inspection method

Measure the outer radius as shown in the figure.

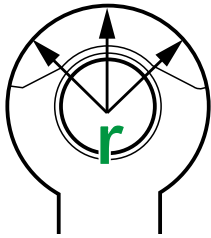

Requirements, wear limits, etc.

Minimum radius R according to the table.

Type	Min. radius (mm)
SS 57	90
ISO 50	55
DIN 40	48
CH	55

Instructions for rectification



Replace the drawbar eye if the measured R is less than the specified dimension in the table "Min. Radius".

1

NB: Welding is prohibited.

Check whether the drawbar eye is bent vertically and/or laterally.
Check that the welding and bolted joints are free of cracks.
Check that the flange/shank of the eye are free of cracks. Measure dimensions A and C and D on the drawbar eye/drawbar's centre line; see picture.

Assessment, no cracks are permitted.

A ≤ 2 mm
B, C ≤ 2 mm

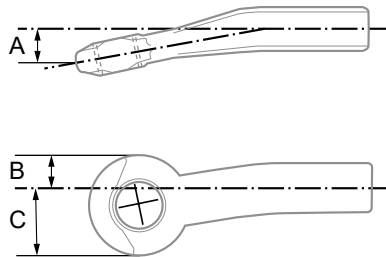

In the event of a bent/overloaded eye, stop driving and immediately visit a workshop, replace damaged parts.

3

If the drawbar eyes are bolted, the bolted joint must be checked and the bolts replaced.
When the components have been dismantled, they must be re-tightened after driving 2,500 km.

NB! Warping a drawbar eye is strictly forbidden.

Also check for any cracks in the geometry adjacent to the drawbar eye, both before and after cleaning.
If you suspect that there is a crack, investigate using liquid penetrant.

No cracks are permitted.



In the event of cracking, stop driving and immediately visit a workshop, replace damaged parts.

3

NB: Welding is prohibited.

Be aware of banging/clicking sounds or jolts when driving with a trailer. Also be aware of any rust forming around the castellated nut and around the contact surfaces between the drawbar eye and sleeve.
Check carefully that there is no movement in the same contact area.

No movement is permitted and there must be no rotation of the castellated nut and/or the drawbar eye in the sleeve.

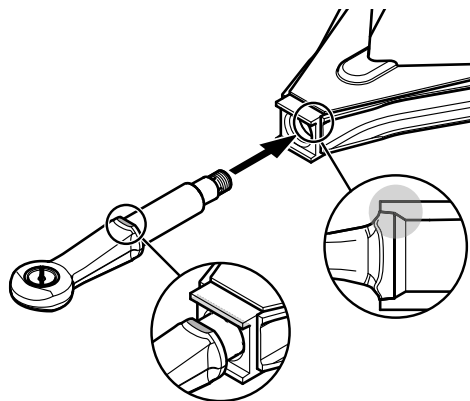

In the event of movement or play, stop driving and immediately visit a workshop to replace damaged parts.
When the parts have been dismantled, re-tightening must take place after driving 2,500 km and a new cotter must be fitted.

2

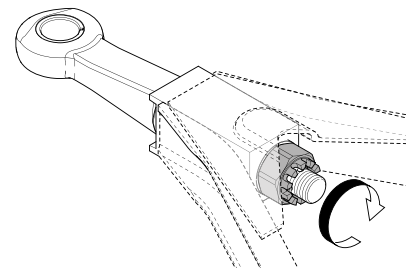



Produced in a certified company

VBG GROUP TRUCK EQUIPMENT GMBH · Girmesgath 5 · D-47803 Krefeld
www.ringfeder-rf.com