

Identification plate

RINGFEDER
RF50 A INT
 for connection with drawbar eye Ø50 DIN 74053 or ISO 1102

55R - 01 10486 Serial No. XXXXX Year YY/WW
 Alt 1: Alt 2:
 D 320kN Dc 135 135 170 kN
 Class: C50-X S 1000 2000 1000 kg
 10090567 Made in Sweden V 75 63 60 kN

Lochbild / Hole pattern

Ø21
 100 ± 0.5
 141 ± 3
 160 ± 0.5
 +6
 203 - 0

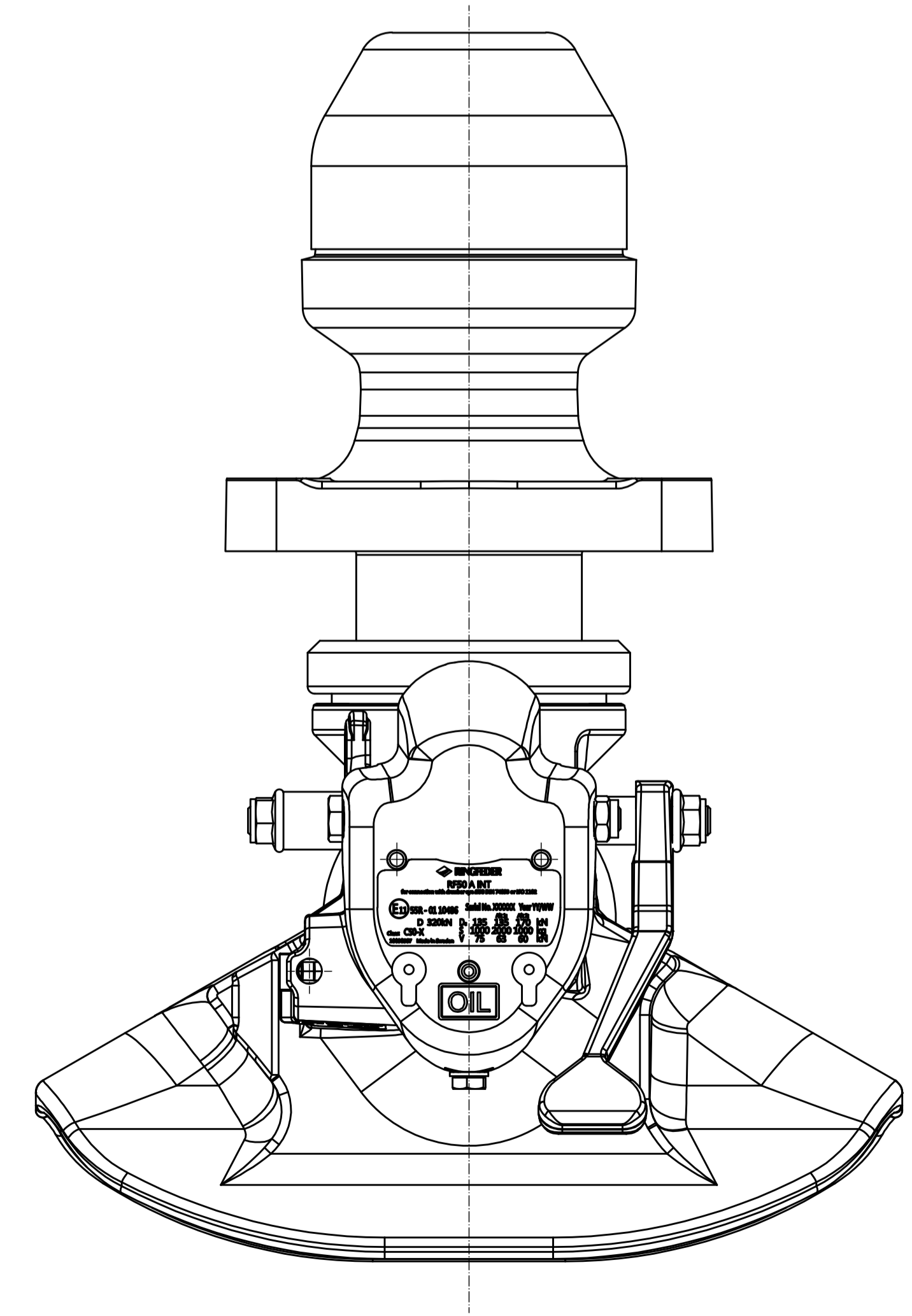

Winkelausschläge der Zugöse:
 Angle of of drawbar eye:

Horizontal ± 90° min
 Vertikal ± 20°
 Axial 360° bei einem Mindestdrehmoment von 100 Nm
 with a minimum torque of 100 Nm

Fastening torques according to mounting instruction
 Anzugsmomente gemäß Montageanleitung

 VBG GROUP		Modified Date	2021-03-02	Modified by	HBH	Modification No.	13001	Issue	a
		3D Model No.	15990624	Engineer	HBH				
Description		Sheet Size	A1	Scale	1:2	Revision	2019-12-16	Drawn by	HBH
RF50 A INT		Stage	P	Drawing No.	15990624(F) Info				

This drawing is the property of VBG Group AB and is protected in accordance with prevailing law. Changes must be made in CAD program, this concerns both 2D & 3D.